



"Custom Solutions for your Application"

EAGLE WATER WELL VISE

Eagle Quality for a Vise You Can Count On

These vises are ruggedly built for oilfield or water well application. Designed for vertical or horizontal use, they are fabricated from steel plate and utilize special gripping jaws for rotational and axial holding. There is no cast material in the vise in order to minimize the risk of material embrittlement and failure under extreme use. This vise accommodates pipe up to 4.5" diameter.

Advantages

- Small footprint for bumper or table mount
- Flush sides for use as horizontal clamp
- Jaws configured for torque and axial holding
- Ergonomic grip for efficient and secure holding

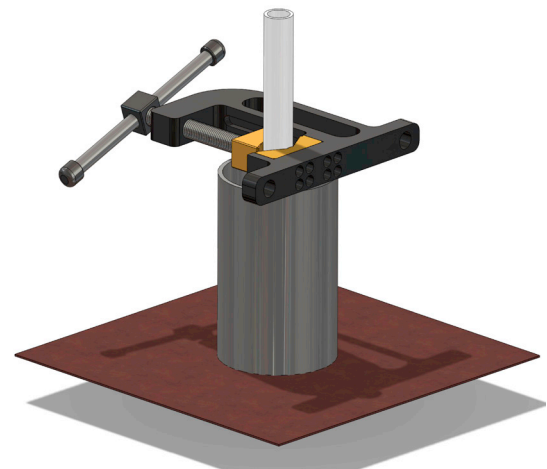
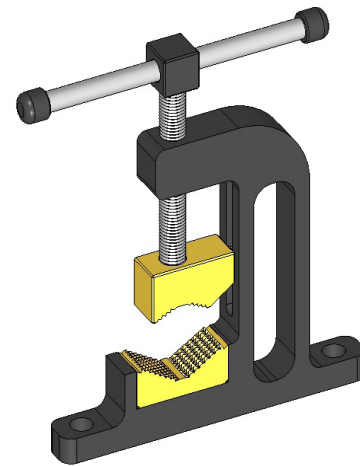
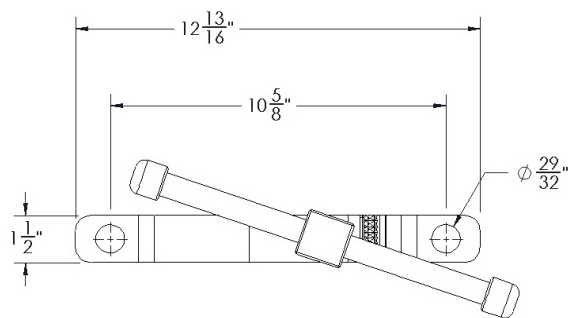

13932 Old Texaco Rd. | Conroe, TX 77302 | www.eagledownhole.com

©Copyright 2009, by Eagle Downhole Solutions, LLC. All rights reserved. Not to be used, transmitted, in any form, or by any means, or copied without prior written permission of Eagle Downhole Solutions, LLC.